

**CLIMA NET AG**  
Kälte- und Klimatechnik

## Trigeneration Systems with Absorption Chillers by Clima Net

There's Only One Earth.  
So there's a Responsibility.

*To protect the earth and to protect the environment is the common issue of the mankind. The traditional electric chiller which takes CFC and H-CFC as its cooling medium has caused great harm to the ozone layer of the atmosphere., which can never be tolerated by the mankind. The far-sighted personnel in the field of refrigeration and air conditioning cannot turn a blind eyes to this phenomenon.*

*The lithium bromide absorption chiller adopts solution of Lithium bromide as its working medium, which is non-volatilization, non-deterioration, and pollution- free.*

*Clima Net flue gas type lithium bromide absorption chiller/heater, with its high energy efficiency and outstanding environment-friendly performances, can save dioxide, etc., having positive influences in anti-air pollution and improvement of energy utilization. Because of the high energy efficiency and outstanding environmental benefits. Clima Net flue gas type units are enjoying more and more popularity among users.*

*Clima Net, with more than 20 years of experiences in Absorption technology, offers world-leading technical support for each type of products and provides each user with ardent and most favorite services.*

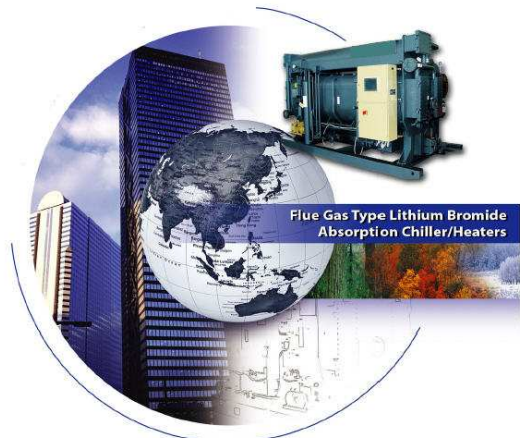

***Trigeneration(CCHPI BCHP) - the only  
Choice of Development for Power Supply with  
Lithium Bromide Absorption Chiller Heater  
The only Choice for Trigeneration.***

## **Trigeneration System**

Trigeneration (CCHP/BCHP), which applies the oil or gas as the prime energy resource to meet the requirements of community or buildings for the power, heating and/or cooling, can realize the cascade resources applications, such as the high grade energy is used for power generation, and less potential energy for heating and/or cooling to raise the utilization percentage of power to 80%, improve the safety of power supply by electric power network, save energy considerably, protect environment and continuous develop national economy. Application of trigeneration, which gives additional power supply to the society and reduces the energy consumption by air conditioning installations, has the active role to solve the power supply shortage. So, the trigeneration system is the only choice of development of power supply.

In the trigeneration system, the lithium bromide absorption chiller/heaters, operated by high temperature flue gas (or flue gas and waste hot water), can fully utilize the low potential heat energy, efficiently improve the integrated energy application percentage. Summing up, lithium bromide absorption chiller is the best heat recovery units in the trigeneration systems.

(The waste heat, which usually is discharged into atmosphere, now is utilized to drive the lithium bromide absorption chiller/heater(LBAC/H), realized the cascade application of prime energy resource.)

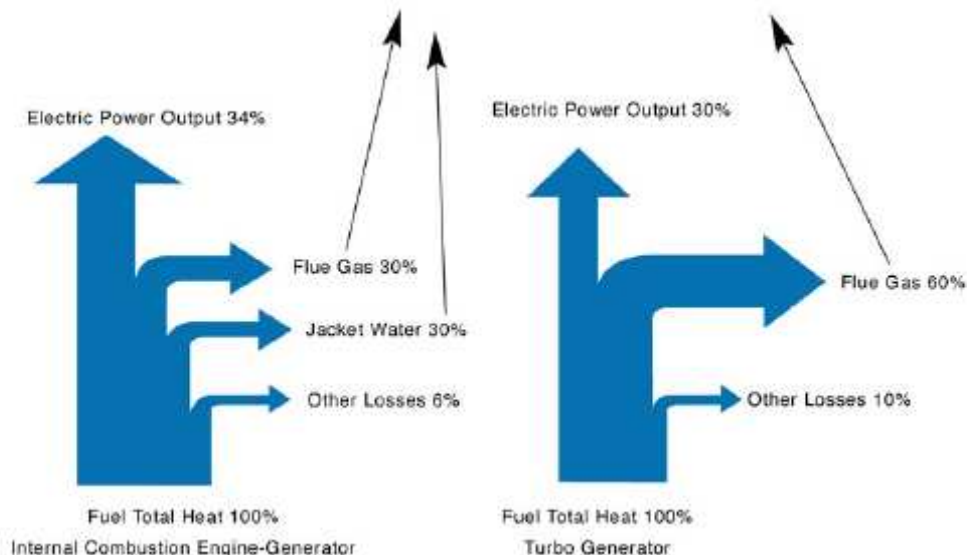

Trigeneration system can be widely used in places where electric power and air conditioning requirements exist simultaneously, such as factories, hospitals, large department stores, communities and industrial parks.

# Flue Gas Type Lithium Bromide Absorption chiller/heaters

Flue gas type lithium bromide absorption chiller/heaters are operated by the flue gas from generators and other heat sources, fall into two categories: flue gas type and flue gas/hot water type. High temperature flue gas type absorption chiller/heaters are mainly applicable to the trigeneration installations with turbo generators (including micro turbine) and other places where high temperature flue gas is available and air conditioning is necessary (such as industrial kilns). For flue gas-hot water fired types, main heat sources can find the flue gas and jacket water from internal combustion engine. These types can also be used in other places where high temperature flue gas is available and air conditioning is necessary.

In order to meet the requirements to comfort and technological needs of air conditioning system, lithium bromide absorption chiller/heaters with after-burning means can be installed, where heat from generator flue gas (or flue gas and hot water) is not enough to drive them.

For trigeneration installation with internal combustion engine as drive, if flue gas is enough to meet the requirements of air conditioning, and hot water will be used for other applications, then flue gas type or such type with after-burning will be available.

## Typical Modes for Application of Trigeneration System with Flue Gas type Lithium Bromide Absorption Chiller/Heaters

### Mode 1. Gas Turbine+Flue Gas Type Lithium Bromide Absorption Chiller

#### Working Principle:

Fuel is burned in the gas turbine combustion chamber to produce high pressure and temperature gas to drive gas turbine generator, flue gas of which is directed to lithium bromide absorption chiller/heaters to offer chilled (hot) water for air conditioning.

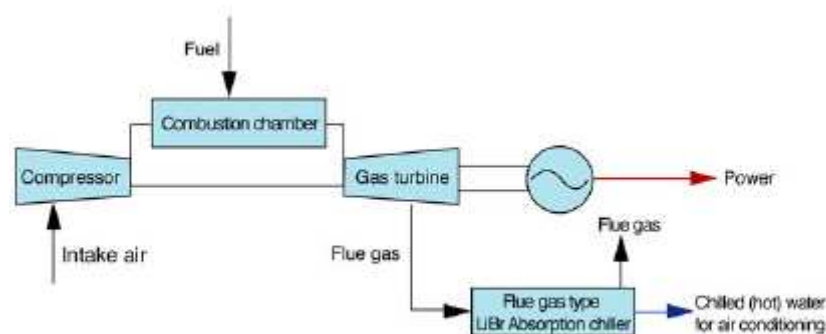

### Application Features:

Gas turbine generator is working based on simple circle, which is beneficial to improve rate of chilled and hot output.

flue gas from gas turbine is used in flue gas type lithium bromide absorption chiller/heater. to simplify the installation configuration. save equipment investment, and improve the energy integrated utilization in system.

This mode is applicable to the trigeneration system with gas turbo generator.

## Mode 2. Gas Turbine+Flue gas type Lithium Bromide Chiller/Heater with after burning

### Working Principle:

Fuel is burned in the gas turbine combustion chamber to produce high pressure and temperature gas to drive gas turbine generator, flue gas of which is directed to lithium bromide absorption chiller/heaters with after burning to offer chilled (hot) water for air conditioning. When the flue gas can not meet the cooling capacity required by air-conditioning, the after burning system is started to supply additional portion of fuel into the combustion chamber of absorption chiller/heater.

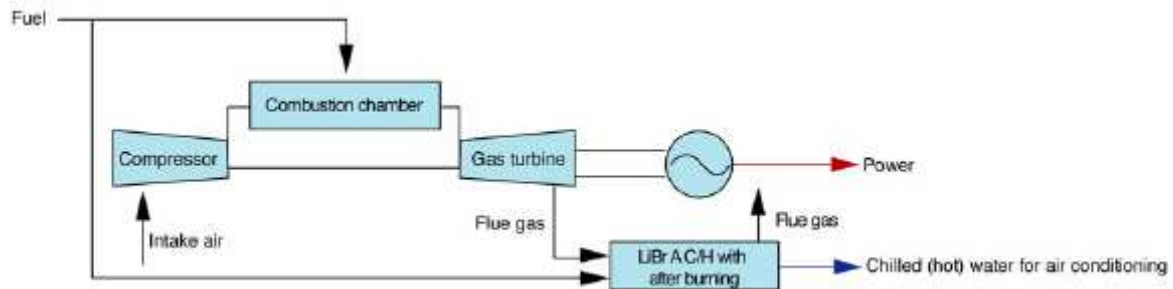

### Application Features:

Gas turbo generator is working based on simple circle, which is beneficial to improve rate of chilled and hot output.

Flue gas from gas turbine is used in flue gas type lithium bromide absorption chiller/heater with after burning, to simplify the installation configuration, save equipment investment, and improve the energy integrated utilization in system.

Installation of flue gas type lithium bromide absorption chiller with after burning allows rational configuration of generator and chiller/heater capacity based on the air conditioning system cooling and heating load, safe equipment investment, and improve the energy integrated utilization in system.

This mode is applicable to the trigeneration system with gas turbo generator

## Mode 3 Internal Combustion Engine +Flue Gas/Hot Water Type Lithium Bromide Absorption Chiller/Heater

### Working Principle:

Fuel is burned in the engine combustion chamber to produce mechanical power for driving generator. Engine high temperature flue gas and jacket hot water is directed to lithium bromide absorption chiller/heaters to offer chilled (hot) water for air conditioning.

Engine circulating jacket water is directed to water-water heater exchanger to supply heating when the system is running.

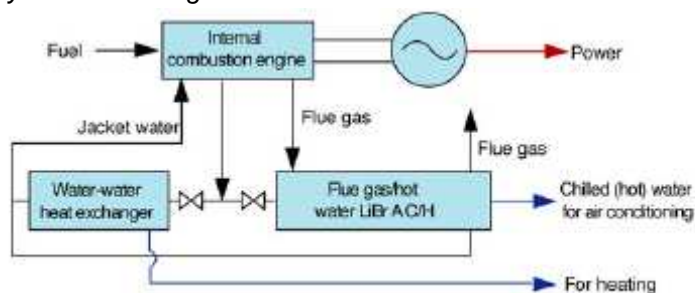

## Application Features:

Internal combustion engine flue gas and jacket water can be used directly to operate flue gas/ hot water type absorption chiller to simplify equipment configuration, reduce equipment investment and improve the system integrated energy utilization.

This mode is applicable to the trigeneration system with internal combustion engine driven generators

### Mode 4. Internal Combustion engine + Flue gas/ hot water operated Absorption chiller/Heater with after burning

#### Working Principle:

Fuel is burned in the engine combustion chamber to produce mechanical power for driving generator.

Engine high temperature flue gas and jacket hot water is directed to lithium bromide absorption chiller/heaters with after burning to offer chilled (hot) water for air conditioning.

Engine circulating jacket water is directed to water-water heater exchanger to supply heating when the system is running.

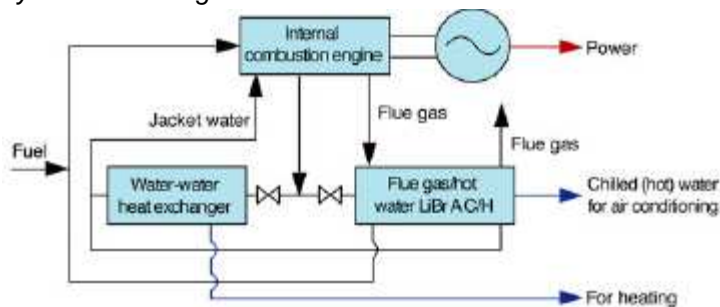

## Application Features:

Internal combustion engine flue gas and jacket water can be used directly to operate flue gas/hot water type absorption chiller with after burning to simplify equipment configuration, reduce equipment investment and improve the system integrated energy utilization.

Installation of flue gas and hot water operated lithium bromide absorption chiller with after burning allows rational configuration of generator and chiller/heater capacity based on the air conditioning system cooling and heating load, save equipment investment, and improve the system operation economy.

This mode is applicable to the trigeneration system with internal combustion engine driven generators.

## **Description of Different Types of Flue Gas Type Lithium Bromide Absorption Chiller/Heaters and Their Applications**

<b>Type</b>	<b>Flue Gas Type</b>	<b>Flue Gas type with After Burning</b>	<b>Flue Gas / Hot Water type</b>	<b>Flue Gas / Hot water Type with After Burning</b>
Function	Cooling/heating	Cooling/heating	Cooling/heating	Cooling/heating
Cooling capacity	30-800 10'kcal/h	30-800 10'kcal/h	30-800 10'kcal/h	30-800 10'kcal/h
Heat source	High temperature flue gas	High temperature flue gas, gas (oil)	High temperature flue gas, hot water	High temperature flue gas, hot water, gas (oil)
Heat source characteristics	Flue gas temp.250t	Flue gas temp.250-C Natural gas. LPG, city gas, light and heavy fuel oil	Flue gas temp.z250-C Hot water temp.z90°C	Flue gas temp.z280'c Hot water temp.90t Natural gas, LPG, city gas, light and heavy fuel oil
Design life. Year	20	20	20	20
Applications	Places, where high temp. flue gas (with low content of sulphur and foreign matter) is available and air conditioning is necessary.	Places, where high temp. flue gas (with low content of sulphur and foreign matter) is available and air conditioning is necessary.	Places, where high temp. flue gas (with low content of sulphur and foreign matter) and hot water is available and air conditioning is necessary.	Places, where high temp. flue gas (with low content of sulphur and foreign matter) is available.
Application Features	Applied mainly for trigeneration system with gas turbine (including micro turbine), internal combustion engine, fuel cell as generator drive, also can be used for cooling (heating) by high temperature flue gas (such as flue gas of industrial kilns)	Applied mainly for trigeneration system with gas turbine (including micro turbine), internal combustion engine, fuel cell as generator drive. also can be used for cooling (heating) by high temperature flue gas (such as flue gas of industrial kilns)	Applied mainly for trigeneration system with internal combustion engine as generator drive, also can be used for cooling (heating) by high temperature flue gas (such as flue gas of industrial kilns) and waste hot water.	Applied for gas turbine generator plant. micro turbo generators, and internal and external combustion engine

# Flue gas type absorption chiller/heaters

## Working Principle

### Refrigerating cycle and its Features

Flue gas type lithium bromide absorption chiller/heater is a equipment, which uses high temperature flue gas discharged by gas turbine installation, as fuel, water as refrigerant, lithium bromide as absorbent solution, produces chilled and/or hot water for the purpose of air-conditioning and technology process. It consists of flue gas high pressure generator (HP generator), low pressure generator (LP generator), condenser, evaporator, absorber, high temperature heat exchanger (HT heat exchanger), low temperature heat exchanger (LT heat exchanger), and such auxiliary parts, as hermetically-sealed pumps and vacuum pump, and keeps itself under vacuum conditions by vacuum pump and automatic purge unit

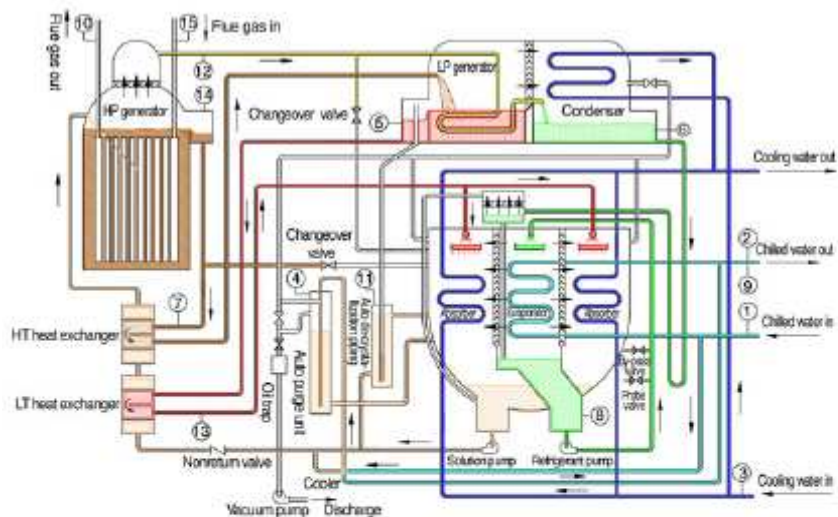

- |                                    |  |                                      |                                      |              |
|------------------------------------|--|--------------------------------------|--------------------------------------|--------------|
| ① Chilled water inlet temp. (I)    | ④ LP generator strong solution temp. (C)       | ⑦ Chilled water flow (A)             | ⑩ Strong solution spraying temp. (C) | (I) -Display |
| ② Chilled water outlet temp. (C/A) | ⑤ Condensing temp. (C/A)                       | ⑧ Flue gas outlet temp. (A)          | ⑪ Solution level of HP (C)           | (C) -Control |
| ③ Cooling water inlet temp. (C/A)  | ⑥ HF generator intermediate solution temp. (A) | ⑨ Decrystallization piping temp. (A) | ⑫ Flue gas inlet temp. (I)           | (A) -Alarm   |
| ④ Purgin unit pressure (I)         | ⑧ Evaporating temp. (A)                        | ⑬ HP generator pressure (C/A)        |                                      |              |
- 
- |               |                       |                 |                                |
|---------------|-----------------------|-----------------|--------------------------------|
| Chilled water | Cooling water         | Refrigerant     | HP generator refrigerant vapor |
| Weak solution | Intermediate solution | Strong solution |                                |

### Evaporator

Chilled water from customer (about 12°C) enters heat transfer tubes, and evaporates refrigerant water, which is dripped over the tubes. Thus produced chilled water runs from the evaporator at temperature about 7°C into the external system. Refrigerant water absorbs heat from external system, becomes water vapor, and flows into absorber.

### Absorber

Strong lithium bromide solution possesses tremendous water vapor absorbing capacity drips over tubes, absorbs refrigerant vapor, produced in the evaporator, and becomes weak solution. Cooling water from cooling tower enters the heat transfer tubes to cool the strong solution distributed outside tubes and carries away heat (i.e. heat from external system). After absorbing water vapor, solution is diluted and flows into the re-absorption chamber to absorb the refrigerant vapor flashed in the flash

chamber, and with raised temperature and lowered concentration sent to HP generator through heat exchangers.

### **Flue Gas High Pressure generator**

(HP generator) The flue gas is used to heat and boil the lithium bromide weak solution in the HP generator. The weak solution is concentrated into intermediate solution, which flows into the low pressure generator through HT heat exchanger, and produces high temperature refrigerant vapor, which enters LP generator also.

### **Low Pressure generator**

(LP generator) Lithium bromide intermediate solution, which flows from the HP generator via LT heat exchanger and temperature is reduced, is heated by refrigerant vapor, produced in the HP generator, and concentrated to strong solution, which flows into the absorber through LT heat exchanger, produced vapor flows into condenser. Refrigerant vapor, which flows from HP generator, is condensed by heating the solution, and enters condenser also.

### **Condenser**

Cooling water flows through heat transfer tubes to condense the vapor outside the tubes. Produced refrigerant water flows into the flash chamber through U pipe. A part of refrigerant water is flashed to form vapor, which flows into the re-absorption chamber at the bottom of absorber, another part of refrigerant water is cooled, and enters evaporator to produce cooling effect

### **Low temperature heat exchanger**

(a Heat Exchanger) Strong solution from LP generator exchanges heat with weak solution from absorber for raising the temperature of weak solution and recovering heat from strong solution.

### **High temperature heat exchanger**

(HT Heat Exchanger) Intermediate solution from HP generator exchanges heat with weak solution from LT heat exchanger for raising the temperature of weak solution further. Heat exchangers reduced the heat requirements of HP generator, in the mean time, reduced the cooling water requirements. Performance of heat exchangers determines the operation conditions of chiller/heaters.

### **Heating cycle and its features**

Solution in HP generator is heated by flue gas to produce water vapor, which is passed into evaporator via piping. Vapor in evaporator is condensed over the tubes to heating water in the tubes to supply hot water to external system. Strong solution from HP generator flows into absorber, and becomes weak solution by mixing with condensate from evaporator. Weak solution from absorber is pumped to HP generator to be heated.

When cooling mode is changed into heating mode, two changeover valves (see flow diagram) should be opened, and cooling water pump and refrigerant pumps are to be stopped.

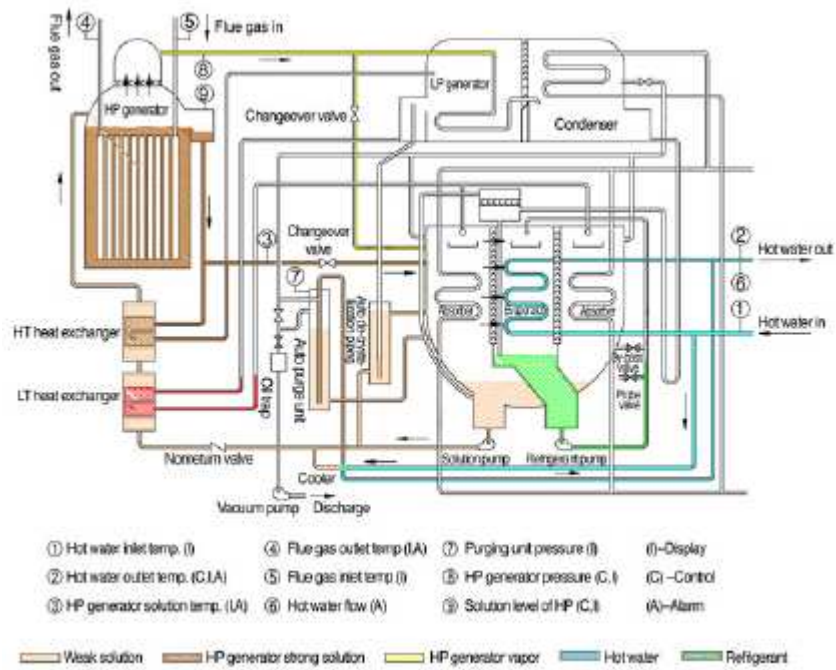

CLIMA NET AG

# Technical Parameters

## Flue Gas Type Absorption Chiller/Heaters Technical Parameters

Type	YX-	35	47	58	70	881	93	116	145	174	204	233	262	291	349	407	465	523	582	698	930		
Cooling capacity	kW	350	470	580	700	810	930	1160	1450	1740	2040	2330	2620	2910	3490	4070	4650	5230	5820	6980	9333		
	10 <sup>4</sup> kcal/h	30	40	50	60	70	80	100	125	150	175	200	225	250	300	350	400	450	500	600	800		
	USRT	99	132	165	198	231	265	331	413	496	579	661	744	827	992	1157	1323	1488	1653	1984	2645		
Heating capacity	10 <sup>4</sup> kcal/h	23.88	31.84	39.80	47.75	55.71	63.67	79.59	99.49	119.39	139.28	159.18	179.08	198.98	238.77	278.57	318.36	358.16	397.95	477.54	636.72		
Chilled(Hot) water	Flow rate	m <sup>3</sup> /h	60	80	100	120	140	160	200	250	300	350	400	450	500	600	700	800	900	1000	1200	1600	
	Pressure loss	mH <sub>2</sub> O	2.5	2.5	2.5	2.5	2.5	3.0	3.0	4.9	6.0	5.0	6.3	6.3	7.3	7.3	6.0	10.1	9.8	2.6	3.8	5	
	Connection diameter(DN)	mm	100	100	125	125	150	150	150	200	200	200	250	250	250	300	300	350	350	350	400	450	
Cooling water	Flow rate	m <sup>3</sup> /h	86	114	143	171	200	228	286	356	428	499	570	641	713	855	998	1140	1283	1426	1711	2288	
	Pressure loss	mH <sub>2</sub> O	6.9	6.9	6.9	6.9	6.9	4.5	4.5	6.3	6.6	6.0	10.0	10.0	12.6	12.6	11.0	5.9	5.9	7.4	12.3	13	
	Connection diameter(DN)	mm	100	125	150	150	150	200	200	200	250	250	250	300	300	350	350	400	400	400	450	500	
Flue gas	Flow rate	kg/h	2355	3140	3925	4710	5495	6280	7850	9813	11775	13738	15700	17663	19625	23550	27475	31400	35325	39250	47100	62800	
	Pressure loss	mmH <sub>2</sub> O	120	130	130	130	140	150	150	170	185	185	170	175	175	185	185	175	180	170	190	200	
	Inlet diameter(D)	mm	300	300	350	350	400	400	450	500	550	550	600	600	700	700	800	800	900	900	1000	1100	
	Outlet diameter	mm	250x500	300x550	350x600	400x650	420x700	450x750	500x800	550x850	600x900	600x1000	600x1100	700x1200	700x1300	800x1400	800x1500	900x1650	900x1750	1000x1850	1000x1950	1100x2000	1300x2250
Power supply	3Ø380V/50Hz																						
Electric power	Total current	A	11.4	12.6	12.6	15	15	15.6	16.5	17.7	17.7	20.7	23.7	23.7	25.2	28.8	30.3	33.3	33.3	37.8	42.3	58	
	Electric power	kW	3.15	3.55	3.55	4.35	4.35	4.55	4.85	5.25	5.25	6.25	7.25	7.25	7.75	8.95	9.45	10.45	10.45	11.95	13.45	17.95	
	Solution pump	kW	2.0	2.4	2.4	2.8	2.8	3.0	3.0	3.4	3.4	4.0	5.0	5.0	5.5	6.0	6.5	7.5	7.5	9.0	10.5	15	
	Refrigerant pump	kW	0.4	0.4	0.4	0.8	0.8	0.8	1.1	1.1	1.1	1.5	1.5	1.5	1.5	2.2	2.2	2.2	2.2	2.2	2.2	2.2	
	Vacuum pump	kW	0.75	0.75	0.75	0.75	0.75	0.75	0.75	0.75	0.75	0.75	0.75	0.75	0.75	0.75	0.75	0.75	0.75	0.75	0.75	0.75	
Overall dimensions	Length	mm	3750	3780	3790	3810	3840	4305	4330	4800	4830	5285	5680	5740	6340	6460	6460	6460	7470	7470	8213	9318	9560
	Width	mm	2288	2418	2588	2808	2943	2978	3258	3543	3895	4095	4180	4345	4350	5005	5300	5525	5962	5807	6027	7000	
	Height	mm	2152	2171	2169	2279	2364	2364	2489	2564	2778	2887	2909	3126	3127	3426	3730	3750	4078	4088	4250	4800	
Shipping weight	t	7.1	8.6	9.8	11	12.3	13.2	14.4	17.4	20.4	23.1	26.2	29	31.3	37.5	40.7	44.5	49.9	53.7	60.8	74		
Operating weight	t	8.4	10	11.7	13.6	15.2	16.6	18.2	22.5	26.6	30.6	34.6	38.9	42.8	51.1	56.6	62.2	69.1	75	86.5	108		

### Note

Chilled water inlet/outlet temperature 12°C / 17°C; Allowed lowest outlet temperature 5°C .

Hot water inlet/outlet temperature 56-C/60°C •

Flue gas inlet temperature 520°C Outlet temperature: 170°C for cooling operation, and 130°C for heating.

Cooling water inlet/outlet temperature 32/38°C; Inlet temperature is allowed to be changed in the limits of 18--34°C.

Chilled / Hot and cooling water flow rate can be adapted in the limits of 60-120% .

Chilled / Hot and cooling water scale coefficient:0.086m<sup>2</sup>K/kW(0.0001m<sup>2</sup> h °C /kcal).

Load can be adjusted in the limits of 25-100%.

For normal pressure type, the chilled (hot) and cooling water box can bear maximum pressure of 0.8MPa.

Transportation rack for chiller / heater is manufactured with height of 180mm. For chiller / heater model YX-262 and larger, the transportation rack is submerged, and shipping height will be increased for 60mm.

For chiller / heater tested in the manufacturer, all solution is charged into it, and 60% is remained in it, while other solution is required to be discharged.

In the shipping weight the transportation rack weight is included, and solution weight is excluded.

## **Flue Gas Discharge System**

- *Flue gas channel and chimney should be designed to keep the pressure at the outlet between -5 to 0 mmH<sub>2</sub>O.*
- *For a machine room, a chimney can be installed. Chimney is designed with height calculated by formula(in m):  $6L-N$ , where L is the length of horizontal section of chimney, N is the number of turns. Actual chimney height should not be less than calculated value or 8m, and for 3m higher than the surrounding high building, if it exists. In the mean time the chimney height should comply the local code or environmental provisions.*
- *The section of flue gas channel and chimney should be not less than the section of discharge port of unit. The general flue gas piping should have section not less than the sum of sections of branches, which should have valve and its opening indication.*
- *Flue gas for flue gas/hot water) type chiller/heater should have flop valve and compensation joint in its flue gas exhaust piping before the chimney and gas exhaust piping connection, if turbo and/or internal combustion engine generator have chimney connected with flue gas exhaust piping of chiller/heater.*
- *The round section and turns with arc construction of piping should be preferred, and the construction shown in the Figure should be adopted for the branches join together, and converging and expanding construction for the protecting cap, lightning rod and wind protecting cover. Rain protecting cap should have diameter equal to two times of diameter of chimney. The place of outlet of chimney should be chosen far from cooling tower and aft inlet for trigeneration equipment, and to easy observation of smoke.*
- *The horizontal section of flue gas channel should have trap on its lowest section above the equipment, which shall connected with the drain piping led from flue gas box of chiller/heater unit, and through 200mm U-shaped trap drained to the ditch.*
- *Chimney should be constructed with bricks and concrete in order to avoid corrosion. The pipe thickness should be not less than 4mm, if the steel construction is adopted. For compensation the heat expansion of chimney, the expansion joint should be provided on the straight section, and soft fire retarded and heat resisted material should be placed, when the flue gas pipe passes through well and when flange is installed*
- *Flue gas channels should be insulated, when they are checked to have good aft-tightness. insulation material can withstand working temperature of 350°C ( such as rock wool felt or cement-perlite plate ).*

## Construction Schematic of Flue Gas Exhaust Construction

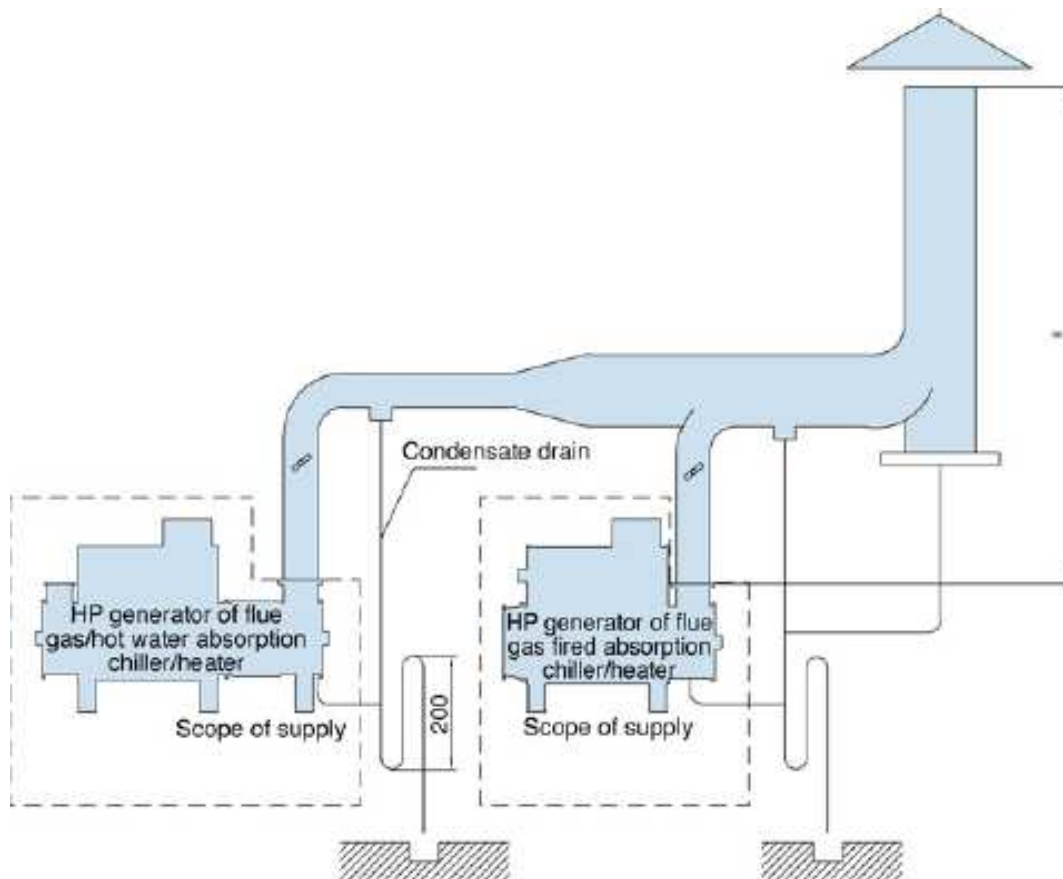

## Appendix

### Power Generation Equipment Supplier

#### Gas turbine with mid-small capacity

SOLAR Company (USA), power output: 1.21MW-5.5MW

KAWASAKI (JAPAN), power output 0.61MW-5.265MW

#### Micro gas turbine

CAPSTONE (USA), 30KW and 60KW available

BOWMAN (UK), 30KW-500KW available

#### Combustion Equipment

CATERPILLAR (USA), CUMMINS (USA), MBE (GERMANY), DEUTZ (GERMANY), GE JENBACHER (AUSTRIA)

**Clima Net AG**  
**Gublenstr. 1**  
**CH-8733 Eschenbach**  
**Switzerland**

**Tel. +41 55 465 20 20**  
**Fax +41 55 465 20 21**  
**www.climanet.ch**  
**office@climanet.ch**